

## Espejo aumento DIVA 2 brazos

Ref

204005

ES



LUZ FRÍA



LUZ NATURAL



LUZ CÁLIDA

### Características

- \* Espejo de aumento con 1 cara y 2 brazos.
- \* Cristal de aumento: x3.
- \* Luz LED: 3 modos de luz (3000-4000-6000K).
- \* Alimentación con cable: 220V/ 50 Hz y enchufe tipo C.
- \* Instalación: en pared.
- \* Elementos de fijación: incluidos.
- \* No utilizar disolventes ni productos abrasivos.
- \* Se aconseja el uso de agua y jabón.

### Materiales & Acabado

- \* Base y cubierta posterior fabricadas en acero inoxidable AISI 304
- \* 2 brazos oscilante fabricado en latón.
- \* Acabado: cromo brillo.

### Medidas & Peso (alt. x anc. x fon.)

- \* Diámetro cristal: 21.5 cm.
- \* Diámetro fijación: 12 cm
- \* Dimensiones: 215 x 470 mm.
- \* Peso: 1.167 kg.

### Logística Info (alt. x anc. x fon.)

- \* Caja individual: 310 x 290 x 145 mm.
- \* Peso caja individual: 1.508 kg.
- \* Caja máster: 740 x 300 x 640 mm.
- \* Peso caja máster: 16 kg.
- \* Cantidad: 10 uds.

### Certificaciones

- \* Resistencia a oxidación testada en cámara nieblas salinas con resultado superior a las 300 h.
- \* Conforme a las normas:
  - UNE-EN 60598-1: "Luminaria, reglas y generalidades sobre ensayos".
  - UNE-EN 60598-2-6: "Luminarias con transformador integrado".
  - Acorde con la normativa CE.

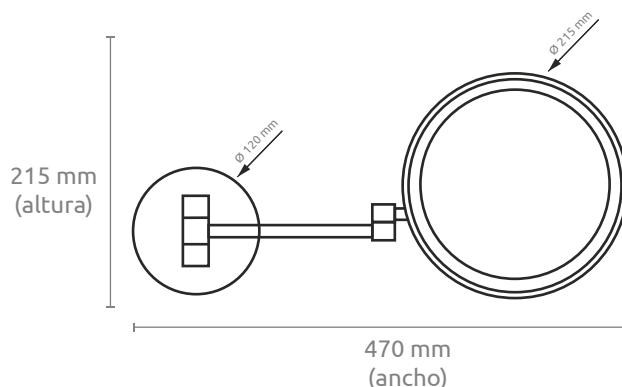

## Magnifying mirror DIVA 2 arms

Ref

204005

EN



COOL  
LIGHT



NATURAL  
LIGHT



WARM  
LIGHT

### Features

- \* Magnifying mirror with 1 side and 2 arm.
- \* Magnifying cristal: x3.
- \* LED light: 3 color light effect mode (3000-4000-6000K).
- \* Cable Power supply: 220V/ 50 Hz and type C plug.
- \* Installation: wall- mounted.
- \* Fixing elements: included.
- \* Do not use solvents or scouring agents.
- \* Soap and water is recommended for cleaning.

### Materials & Finishes

- \* Base and back cover made of AISI 304 stainless steel.
- \* 2 swing arm made of brass.
- \* Finish: bright chrome.

### Measurements & Weight (h x w x d)

- \* Glass diameter: 21.5 cm.
- \* Fixing diameter: 12 cm
- \* Dimensions: 215 x 470 mm.
- \* Weight: 1.167 kg.

### Logistics Info (h x w x d)

- \* Individual box: 310 x 290 x 145 mm.
- \* Weight single box: 1.508 kg.
- \* Master box: 740 x 300 x 640 mm.
- \* Master box weight: 16 kg.
- \* Quantity: 10 pcs.

### Certifications

- \* Resistance to oxidation tested in a salt spray chamber with a result of more than 300 hours.
- \* In accordance with the standards:
  - UNE-EN 60598-1: 'Luminaire, rules and generalities on testing'.
  - UNE-EN 60598-2-6: 'Luminaires with integrated transformer'.
  - In accordance with EC regulations.

